



## FP2005 QE20 RS485 Network Module Installation Instructions

### 1. General Description

This sheet describes installation of the QE20 RS485 Network Module. The RS485 Network Module is used to provide a networking interface (either RS485 copper cables or fibre-optic cables) in a QE20 system.

Generally, one FP2005 RS485/Network Module is needed in a networked QE20, however a 2<sup>nd</sup> needs to be fitted for “joined” audio segments.

For a fibre optic network one of these fibre network kits will also be required to match the type of fibre used.

- FP2024FP, QE20 FIBRE NETWORK KIT, SINGLE MODE
- FP2025FP, QE20 FIBRE NETWORK KIT, MULTI MODE

The RS485 Network Module provides:

- Two separately isolated RS485 ports with 4-wire (separate TX/RX) / 2-wire connections with optional earth fault supervision (in conjunction with the QE20 Controller Module)
- Two network audio connections for Speech (PA) and WIP with optional EOL supervision
- Two non-isolated GP inputs with 4-state supervision for general purpose functions.
- Two non-isolated open-collector GP outputs with optional load supervision for programmable functions.
- One RJ45 Ethernet connector for connection to the QE20 Controller.
- One TTL Serial port for connection to the PIB in the optional FP2024/5 Fibre Network kit
- PA and WIP Audio connections to the VIF module in the Fibre Network kit
- One QComms port for connection to the VIF module in the Fibre Network kit
- WIP AUDIO CHAIN LEFT & RIGHT connections to WIP/INPUT Modules and the Controller.
- Two RS232 ports (currently not supported)
- QBus port (currently not supported).

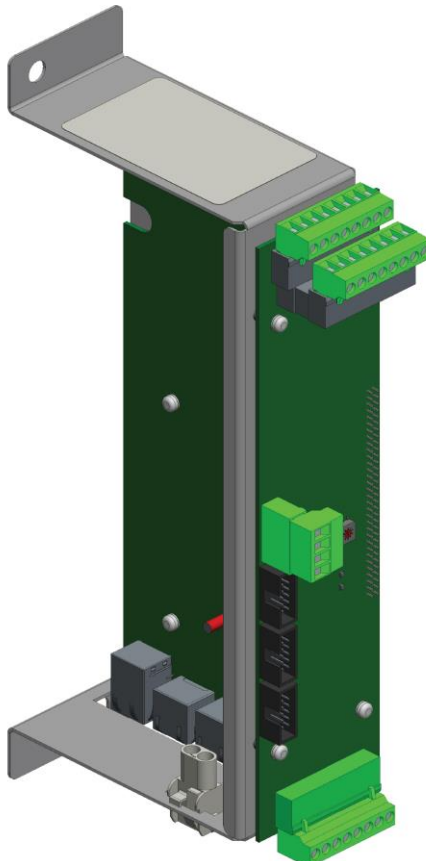

Figure 1 – FP2005 QE20 RS485 Network Module

## 2. Kit Contents

The FP2005 kit contains:

- 1 X QE20 RS485 Network Module
- 1 x RJ45 Ethernet lead 200mm long for connection to the Controller Ethernet Port
- 1 x RJ45 Ethernet lead 300mm long for connection to the Controller Right WIP Chain Audio
- 2 x RJ45 Ethernet lead 1.2mm long for connections between frames
- 2 x M6 x 10 screws to secure the module onto the mounting frame
- 1 x LT0700, these instructions.

## 3. Mounting the RS485 Network Module

The RS485 Network Module is positioned on a QE20 mounting frame, occupying one of the 60mm positions as shown in Figure 2. Usually, it is located next to the Controller. If the FP2024/5 Fibre Network Kit is being installed as well, then this is usually mounted alongside (it requires 180mm of width – three mounting positions). The leads are long enough for it to be located in the frame above or below the RS485 Network Module – depending where on the frames the two modules are positioned and the cable route taken. Refer to LT0714 for details on mounting and wiring the Fibre Network kit.

The RS485 Network Module is secured to the frame using two M6 x 10 screws. Loosely fit a screw to the bottom hole of the desired position, then slide the open slot at the bottom of the RS485 Network Module under the screw head and then fit the top screw to secure the module. Tighten both screws to secure the module into position.

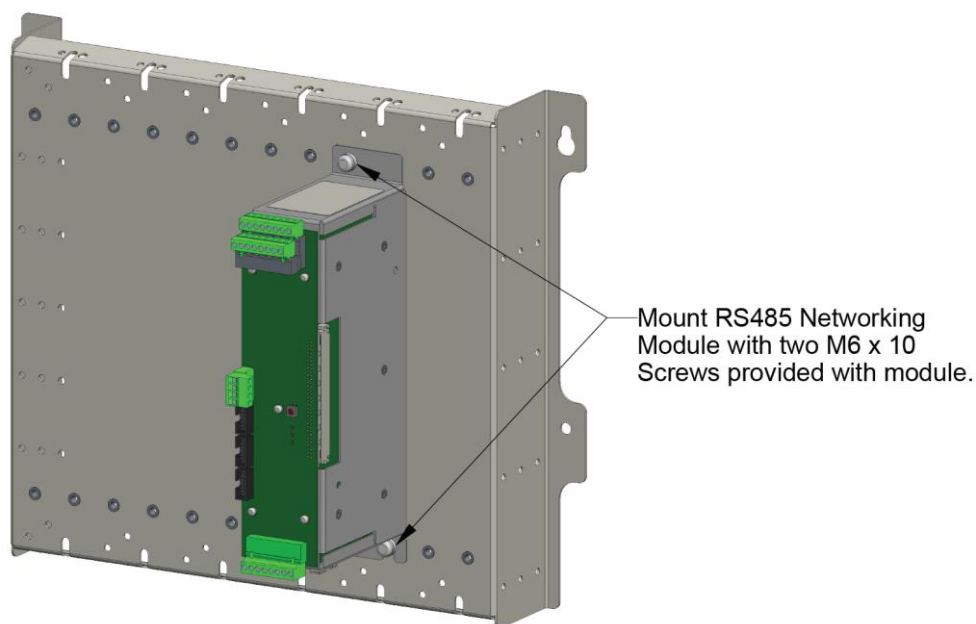

Figure 2 – QE20 RS485 Network Module Mounting

## 4. Replacing an Existing Module

When replacing an existing RS485 Network Module, set the Address switch and links to match the replaced module's settings. The Address switch needs to be set to 1 for the first (main) network Module and 2 for the 2<sup>nd</sup> Network Module, if fitted. The position of the "0" point may be different between the old and new module – use the physical labelling on the switch for the position.

Label the existing wiring / connectors to the RS485 Network Module to identify where the internal and field wiring terminates.

Unplug the network, GP Input and Output, and Fibre Kit connections if present.

Label or identify the RJ45 leads plugged into the RS485 Network Module and then unplug them.

Unplug the power lead to the RS485 Network Module.

Remove the top mounting screw, loosen the lower mounting screw, and lift the module clear of the frame.

Set the links and address switch on the new module to match the one removed.

Position the new module onto the frame with the mounting slot under the lower screw.

Fit the top mounting screw and tighten both screws.

Reconnect the internal and field wiring to the correct points.

Power up and check the operation of the QE20 and, in particular, the network and the GP Inputs and Outputs.

## 5. Fitting a New Module

When adding an RS485 Network Module to an existing QE20, the module will need to be added to and the network functionality set in the QE20 site configuration using QE20Config. Other QE20 panels on the network will probably also need their site configuration changed to include a new QE20 panel.

Refer to the QE20 site configuration for details on using the RS485 Network Module. In particular, whether copper (RS485) or Fibre Networking is being used, if WIP/PA monitoring and earth fault monitoring is enabled, and the functionality of the GP INPUTS and OUTPUTS. For “joined audio networks” the second RS485 Network Module provides the PA and WIP Bus connections for the joined segment.

### ADDRESS Rotary Switch

This needs to be set to the “1” position on the rotary switch for the 1<sup>st</sup> RS485 Network Module, and “2” for the 2<sup>nd</sup> RS485 Network Module.

### Links on RS485/Network Terminal Board

These links are applicable only when copper (RS485) networking is being used. They don't apply with fibre networking.

#### **J12 PORT A**

Fit the 2 x **2-WIRE MODE** links to join TX and RX and create a 2-wire RS485 connection on PORT A (usual). Remove the 2 x **2-WIRE MODE** links to leave TX and RX separate if a 4-wire connection on PORT A is required (unusual).

Fit the **EARTH MON** link if earth fault monitoring is to be enabled on the PORT A RS485 connection via this Network Module. Only 1 Network Module on each loop segment (Port A of one Network Module to Port B of the next Network Module) should have Earth Fault Monitoring enabled. For simplicity, it is suggested each Network Module have earth fault monitoring enabled on Port A and not on Port B. So fit **EARTH MON** on Port A.

#### **J13 PORT B**

Fit the 2 x **2-WIRE MODE** links to join TX and RX and create a 2-wire RS485 connection on PORT B (usual). Remove the 2 x **2-WIRE MODE** links to leave TX and RX separate if a 4-wire RS485 connection on PORT B is required (unusual).

Fit the **EARTH MON** link if earth fault monitoring on the PORT B RS485 connection is to be enabled. For simplicity, it is suggested each Network Module have earth fault monitoring disabled on Port B. So, remove the **EARTH MON** link on Port B.

#### **J14 PA M/S** Master/Slave and EOL selection.

Fit the two **M** links if EOL supervision of the PA network wiring is required at this QE20. Only one panel on the network audio segment should have this fitted - refer to the QE20 site configuration for details. It should be the panel at one end of the PA/WIP busses.

Fit the **S** link to connect the EOL resistor on the PA network wiring, if required. Only one panel on the network audio segment should have this fitted – it will usually be the one furthest from the QE20 with EOL supervision enabled.

Remove both **PA M** links and the **S** link for all other panels on the PA network segment.

#### **J15 WIP M/S** and EOL selection.

Fit the two **M** links if EOL supervision of the WIP network wiring is required at this QE20. Only one panel on the network audio segment should have this fitted - refer to the QE20 site configuration for details. It should be the panel at one end of the PA/WIP busses.

Fit the **S** link to connect the EOL resistor on the WIP network wiring, if required. Only one panel on the network audio segment should have this fitted – it will usually be the one furthest from the QE20 with EOL supervision enabled.

Remove both **WIP M** links and the **S** link for all other panels on the WIP network segment.

### Links on RS485/Network Main Board

**LK1 EOL\_D**: QBus EOL select – Not Fitted.

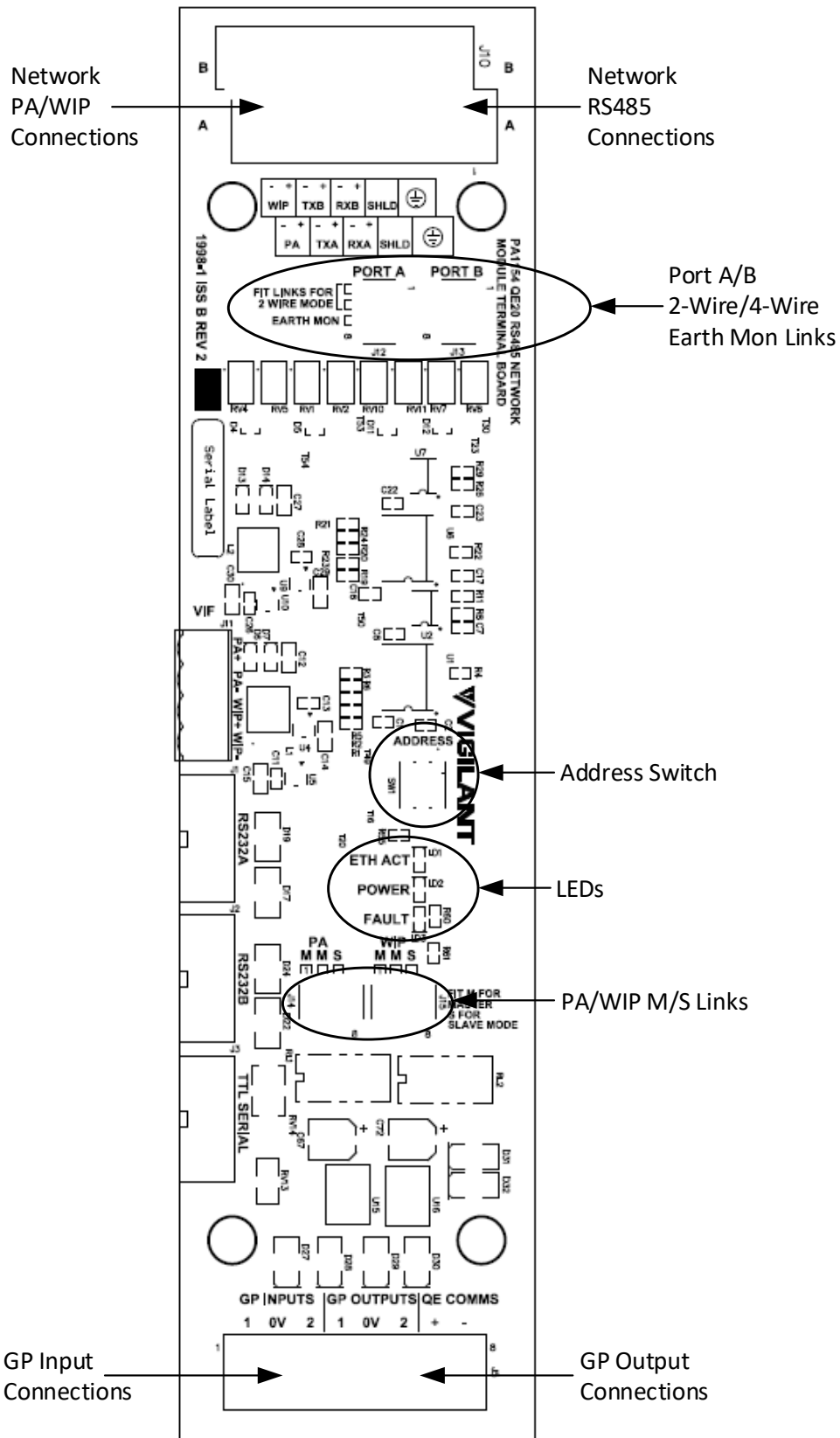

Figure 3 – RS485 Network Module Switch, Link and LED locations

### 5. Internal Wiring

The QE20 RS485 Network Module requires:

- 24V power to be connected to the 24V IN 2-way power connector. Use a spare output of a 3-way LM0656 cable or fit one between the PSE DC output and the RS485 Network Module.
- An RJ45 cable from the WIP AUDIO RIGHT of the Controller, a WIP/INPUT Module, or another RS485 Network Module to WIP AUDIO CHAIN LEFT of the RS485 Network Module.
- An RJ45 cable from the WIP AUDIO CHAIN RIGHT of the RS485 Network Module to the WIP AUDIO LEFT connector on another RS485 Network Module or a WIP/INPUT Module.
- An RJ45 cable from the ETHERNET connector of the RS485 Network Module to ETHERNET Port 2 on the QE20 Controller for the first RS485 Network Module, and to ETHERNET PORT 3 on the QE20 Controller for the second RS485 Network Module.

Refer to Figure 4 for the generalised WIP Audio Chain internal wiring of the Controller, RS485 Network Module and WIP/Input Modules.

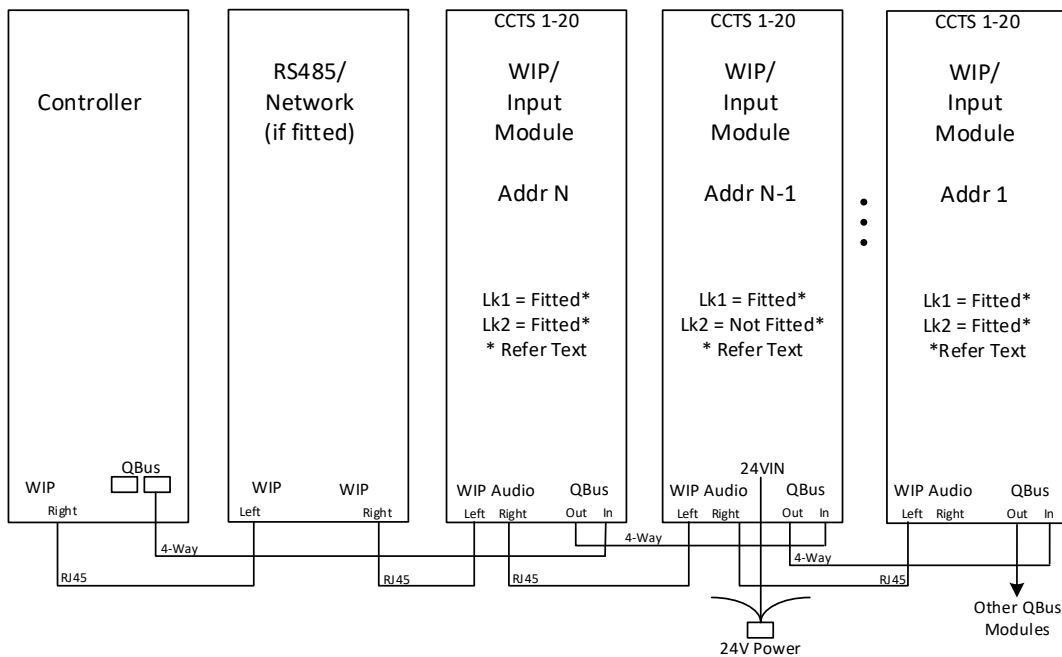

Figure 4 – Generalised WIP Audio Chain Internal Wiring Diagram

If an FP2024/5 Fibre Network Kit is fitted, then the connections to it from the first RS485/Network Module are:

- A 4-way loom carrying PA & WIP audio from VIF J11 to the PA and WIP terminals of the VIF card.
- A 2-way loom from J5 QECOMMS+ to the VIF card QECOMMS terminals.
- A 10-way header loom from J3 TTL SERIAL to J24 on the PIB.

Refer to the LT0714 Installation Instructions provided with the Fibre Network kit for details.

### RS232 Ports

The **RS232A** and **RS232B** serial ports are available on 10-way FRC headers compatible with some “Vigilant” products. Use an LM0065 FRC cable to convert the 10-way header to a DB-9 connector and an LM0076 Null Modem cable to connect to a PC or another DTE RS232 port. Refer to drawing 2001-2 Sheet 603 for wiring details. Currently the RS232 ports have no functionality and should not be connected.

Table 6.1 **RS232A** and **RS232B** Pinout / Functions

Pin Number	Signal / Function	Pin Number	Signal / Function
1	-	6	CTS (input)
2	-	7	-
3	RXD (input)	8	-
4	RTS (output)	9	GND
5	TXD (output)	10	-

**TTL SERIAL Port J3**

The **TTL SERIAL** port J3 provides 5V level serial port signals on a 10-way FRC header compatible with specific “Vigilant” products such as the PIB. Refer to drawing 2001-2 Sheet 604 for wiring details.

**WARNING** – Do not plug RS232 or other incompatible cables into the **TTL SERIAL** header, otherwise damage to the port may result.

**Table 6.2 TTL SERIAL J3 Pinout / Function**

Pin Number	Signal / Function	Pin Number	Signal / Function
1	+24V	6	CTS- (input)
2	-	7	0V
3	RXD- (input)	8	0V
4	TXD- (output)	9	-
5	RTS- (output)	10	+5V

The +24V and +5V outputs are overload protected at 750mA and 500mA respectively.

Currently the only supported functionality is to connect the TTL Port of the first RS485 Network Module to the PIB in the FP2024/5 Fibre Network Kit when fibre networking is used.

**6. Field Wiring**

Refer to the specific QE20 site configuration for the assigned functionality and options for each of the inputs and outputs on the RS485 Network Modules, to determine if copper cable (RS485) or fibre networking is being used, and if there is a “Joined Audio Bus”.

**Copper (RS485) Networking**

The copper network consists of two types of connection between the QE20 panels in the network – RS485 Data arranged in a loop, and PA/WIP Audio arranged as two busses. Refer to drawing 2001-2 Sheet 600 for example wiring. This includes the connection to an optional VIGILANT I-HUB, which must be used for the network connections in the *MX1* FDCIE or other equipment.

**RS485 DATA Wiring**

The RS485 DATA wiring is arranged in a loop around the QE20 RS485 Network Modules and I-HUBs. TXA on one module connects to TXB on the next module, and so on around the loop. Screened cable is required.

The loop in and out cables to each QE20 should be run in separate paths, so that a fault does not sever both cables at the same time.

**PA/WIP Network Wiring**

The PA and WIP Network audio wiring is arranged as two busses between all the panels, with the QE20 at one end supervising the cabling (M links fitted) and the QE20 at the other end providing the EOL resistors (S links fitted). Screened cable is required.

The two busses should be run in separate paths, so that a fault does not sever both cables at the same time.

**Fibre Optic Cable Networking**

Refer to LT0714 for details of installing and wiring the FP2024/5 Fibre Network kit. Drawing 2001-2 Sheet 605 included in LT0714 details the wiring connections between the RS485 Network Module and the Fibre Network kit, and the internal wiring of the Fibre Network Kit.

Do NOT plug the PIB cable into either of the RS232 Ports on the RS485 Network Module! This may damage both the Network Module and the PIB.

If this QE20 is to be a Fibre-Copper Bridge then drawing 2001-2 Sheet 608 included in this manual shows the field wiring for the two RS485 Network Modules.

**Joined Audio Bus Segment**

If an audio bus segment is to be “joined” on to the main network at this QE20, then a second RS485 Network Module is required. This is set to address #2. It connects to +24V Power and into the WIP Audio Chain the same

as the first module. Its Ethernet port is connected to ETHERNET Port 3 on the Controller.

This second RS485 Network Module provides the PA and WIP audio terminals for the “joined” audio bus. Refer to drawing 2001-2 Sheet 607 for the field wiring arrangement.

**GP INPUT Wiring**

The two GP INPUTS support connection of clean contact devices like switches, relay contacts, etc. for functions such as fault detection, class change, time clocks, trial evacuation, and silence alarms. They have fixed 4-band operation (open, EOL device, alarm/active, shorted), and are compatible with on/off, three-way, or four-way switches. Table 3 shows the States, resistance bands and logic tokens available.

Refer to drawing 2001-2 Sheet 601 for example wiring.

Table 3 – GP Inputs- States, Resistance Bands and Tokens Available

Circuit Type	State, Resistance Band, Logic Token			
4 Band	Short < 270R NCIPSCx.y	Alarm 680R NCIPALx.y	Normal 10K NCIPNMx.y	Open > 20K NCIPOCx.y

Where x = Module Address 1 or 2, y = Input Number 1 or 2.

**GP OUTPUT Wiring**

The two GP OUTPUTS are open-collector outputs that switch on (pull down to 0V) when activated. Any load needs to be wired between the output and a suitable supply voltage.

The GP OUTPUTS could be used to turn on an LED, sounder, etc, or be connected to a 24V relay to provide isolated contacts, with suitable programming in the site configuration.

If the GP OUTPUT wiring is enclosed within the QE20 cabinet, then an internal +24V source can be used, such as J5/6 on the MUI module, a spare 24V DC output from a PSE, or the +24V connection inside the Fibre Kit.

If the GP OUTPUT wiring extends outside the QE20 cabinet, then a fused +24V source must be used. Refer to the PSE Installation Guide (LT0694) and Power Distribution Fuse Board Installation Guide (LT0727) for details on providing a fused +24V output from the PSE.

Optional load supervision is supported. In the off state, a fault is generated if the load is disconnected, the load supply falls below 12V, or the output is shorted to 0V. This supervision requires the load to be connected to a supply of at least 12V to not be in fault. If a lower supply voltage needs to be used, then supervision must be disabled in the configuration.

Refer to drawing 2001-2 Sheet 602 for example wiring.

Note each GP OUTPUT contains a 100K pull down resistor for supervision. This means a current of up to 250uA may flow through the load in the off state. For most relays and other high current devices this won't be an issue. However, it may cause an LED to glow or a buzzer to sound quietly. A suitable resistor may need to be wired across the load to bleed off this supervision current.

**7. LED Indications**

There are three LED indicators on the RS485 Network Module.

- **ETH ACT** is on green if an Ethernet connection is present and blinks with Ethernet activity. It is off if there is no Ethernet connection or the Controller is powered down.
- **POWER** is on green, blinking off every few seconds as the RS485 Network Module communicates with the Controller over Ethernet. Off means 24V power is not supplied or the RS485 Network Module is faulty. Steady on means the RS485 Network is not communicating with the Controller – check the Ethernet connection, the address switch and the Site configuration.
- **FAULT** will flash yellow when there is a fault with any of the GP OUTPUTS, RS485/PA/WIP network connections, PIB / Fibre network connections, Controller Ethernet connection, QComms to the VIF, or the RS485 Network module itself. A sequence of 16 flashes is shown, with a long flash indicating that the specific fault is present, and a short flash that the specific fault is not present. For example, if the second flash is long, then GP OUTPUT 2 is in fault – probably open circuit. Refer to Table 7.1 for details.

Table 7.1 FAULT LED Flash Indications

Flash Number	Description	Explanation / Action
1	GP OUTPUT 1 supervision fault	For a supervised GP Output 1: When the output is off – a fault occurs on open circuit to the load, failure of the external supply (<12V), or short circuit of the output to 0V.  When the output is on, an overload can cause a fault. Check the field wiring.
2	GP OUTPUT 2 supervision fault	For a supervised GP Output 2: When the output is off – a fault occurs on open circuit to the load, failure of the external supply (<12V), or short circuit of the output to 0V.  When the output is on, an overload can cause a fault, Check the field wiring.
3	PIB connection fault	The RS485 Network Module is configured for Fibre networking and no response is being received from the PIB. Check the PIB cable is plugged into the TTL Port of the Network Module and power is supplied to the Fibre Networking Kit and PIB.
4	PIB Input Fault	FAS1 Input on the PIB is in fault. Check for the fibre ring being broken (Fault LED on the fibre switch is on) or the fibre switch is powered down or disconnected.
5	Ethernet fault	Ethernet connection to the Controller is open or not configured correctly, or the Address switch is wrong.
6	Watchdog fault	A watchdog fault has occurred. If this does not clear, or keeps occurring, then the RS485 Network Module may be faulty. Check with JCI Technical Support if a firmware update is available, otherwise replace the Module.
7	Active Firmware fault	CRC fault detected in the operational firmware. Check with JCI Technical Support if a firmware update is available, otherwise replace the Module.
8	QECOMMS fault	One or more configured VIF modules is not responding on the QECOMMS port. Check the internal wiring to and addressing of the VIF module(s).
9	Network Port A fault	There is no connection established with the next RS485 Network Module on the RS485 Network Port A.
10	Network Port B fault	There is no connection established with the next RS485 Network Module on the RS485 Network Port B.
11	PA Bus wiring fault	Open or short circuit on the Network PA audio connection. Check the field wiring, and the link settings on this and any other RS485 Network Module.
12	WIP Line wiring fault	Open or short circuit on the Network WIP audio connection. Check the field wiring, and the link settings on this and any other RS485 Network Module.
13	WIP AUDIO LEFT fault	Open or short-circuit on the WIP AUDIO CHAIN LEFT port connection to the Right port of the next module.
14	WIP AUDIO RIGHT fault	Open or short-circuit on the WIP AUDIO CHAIN RIGHT port connection to the Left port of the next module.
15	No configuration	No configuration has been received from the QE20 Controller. Check the Ethernet connection, the address switch of the RS485 Network Modules, the Controller is operating and the site configuration has the RS485 Network Module configured.
16	Other Fault	Refer to the QE20 LCD Fault Recall for details.



## 8. Power On & Testing

Some suggested steps for the initial power up and testing of the RS485 Network Module.

- Power up the QE20 with its site configuration installed. Check for any fault conditions and resolve these.
- If the QE20 is configured to be able to make Speech announcements to, or receive Speech announcements from, another QE20 panel on the network, activate Speech for the appropriate zones at the controlling QE20 and check that the speech announcements are generated at the correct zones at the receiving QE20.
- If the QE20 is configured to ring WIPs, or receive calls from WIPs, at another QE20 panel on the network, press the appropriate WIP button at the controlling QE20 and check the WIP rings at the receiving QE20. Answer the ringing WIP and check that voice communications is working in both directions.
- Check each configured GP INPUT operates as per the site configuration. Activate each of the conditions on each of the inputs and check the QE20 performs the required function.
- Check each configured GP OUTPUT operates as per the site configuration. Generally, the output will be off (not conducting) and switch on when the programmed function is active.

## 9. RS485 Network Module Specifications

Power Requirements	18V – 32Vdc, 115 mA typ @ 24V
Operating Conditions	-5°C to +45°C 10% to 93% RH non-condensing
RS485 Ports x 2	Separately Isolated TX+, TX-, RX+, RX- 4-wire, link selectable 2-wire, optional earth fault detection (removes isolation)
PA Network	~330mV audio, Optional supervision (56k EOL provided by S link).
WIP Network	~330mV audio, Optional supervision (56k EOL provided by S link).
GP INPUTS (2)	Open (>20k), Normal (10k), Alarm/Active (680E), short <270E. Not-isolated. 10k pull-up to 24V supply
GP OUTPUTS (2)	Open Collector pull down 100ma < 1V on; 30Vdc max off Load supervised >12V required for normal. 250uA supervision current when output off.
QBus Port x 2	Not used.
RS232 Ports x 2	10-way FRC Header. RS232 TXD, RXD, RTS, CTS signals. Do not use
TTL Serial	10-way FRC Header. 5V TXD, RXD, RTS, CTS signals. +5V @0.5A, +24V @ 0.75A current limited.
QECOMMS Port	Internal connection to VIF module in Fibre Kit.
WIP AUDIO CHAIN LEFT	QE20 compatible - supervised
WIP AUDIO CHAIN RIGHT	QE20 compatible - supervised
Ethernet	10/100BaseT RJ45 to Controller Port 2 or Port 3

## **10. End User Licence Agreement, Privacy and Licensed Software**

Please refer to the following web page for the Johnson Controls End User Licence Agreement (EULA), Open Source Software (OSS) licences and Privacy information related to this product -

[www.johnsoncontrols.com/techterms](http://www.johnsoncontrols.com/techterms)

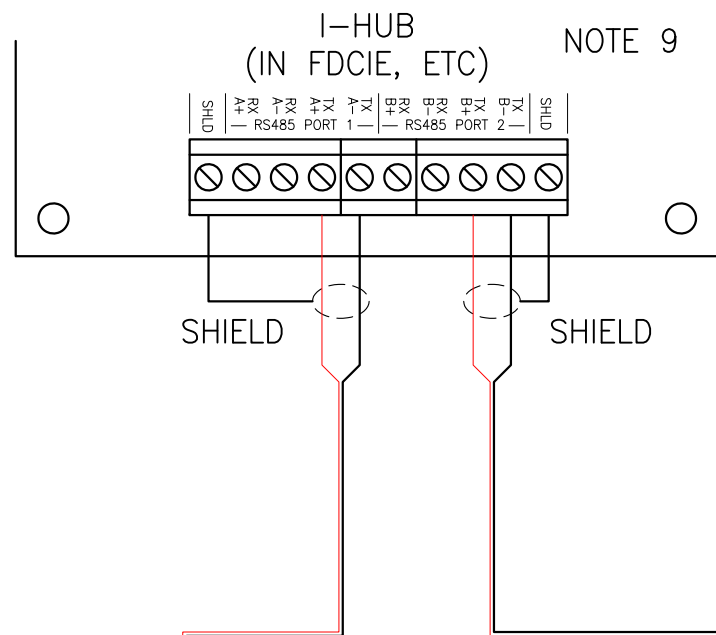

NOTES:

1. EACH CABLE PAIR FIRE RATED & SCREENED. TWISTED PAIR IS RECOMMENDED. 1200M TOTAL CABLE LENGTH MAX.
2. ARRANGE DATA CABLING IN A RING: TXA TO TXB AT NEXT NODE.
3. ARRANGE PA/WIP CABLING IN A BUS, IN/OUT BETWEEN NODES. RUN ONE AUDIO & ONE DATA PAIR SEPARATELY TO OTHER TWO PAIRS.
4. MAINTAIN POLARITY ON ALL PAIRS: + TO +, - TO -.
5. PANEL AT ONE END SHOULD HAVE SUPERVISION ENABLED - FIT M LINKS ON RS485/NETWORK MODULE & ENABLE MONITOR PA & WIP IN SITE CONFIGURATION. FIT PORT A & PORT B EARTH MON LINKS & ENABLE EARTH FAULT SUPERVISION IN SITE CONFIGURATION.
6. PANEL AT OTHER END SHOULD HAVE EOL ENABLED - FIT S LINKS ON RS485/NETWORK MODULE.
7. PANELS BETWEEN NEED M/S SUPERVISION LINKS REMOVED ON RS485/NETWORK MODULE.
8. CONNECT ONE END OF SHIELD TO SHIELD/EARTH TERMINAL. LEAVE OTHER END OPEN.
9. ON RS485/NETWORK MODULES FIT PORT A & PORT B 2 WIRE MODE LINKS. ON I-HUB FIT LK11 - LK14.
10. FOR JOINED AUDIO BUSESSES SEE SHEET 607.
11. FOR FIBRE-COPPER BRIDGE WIRING SEE SHEET 608.

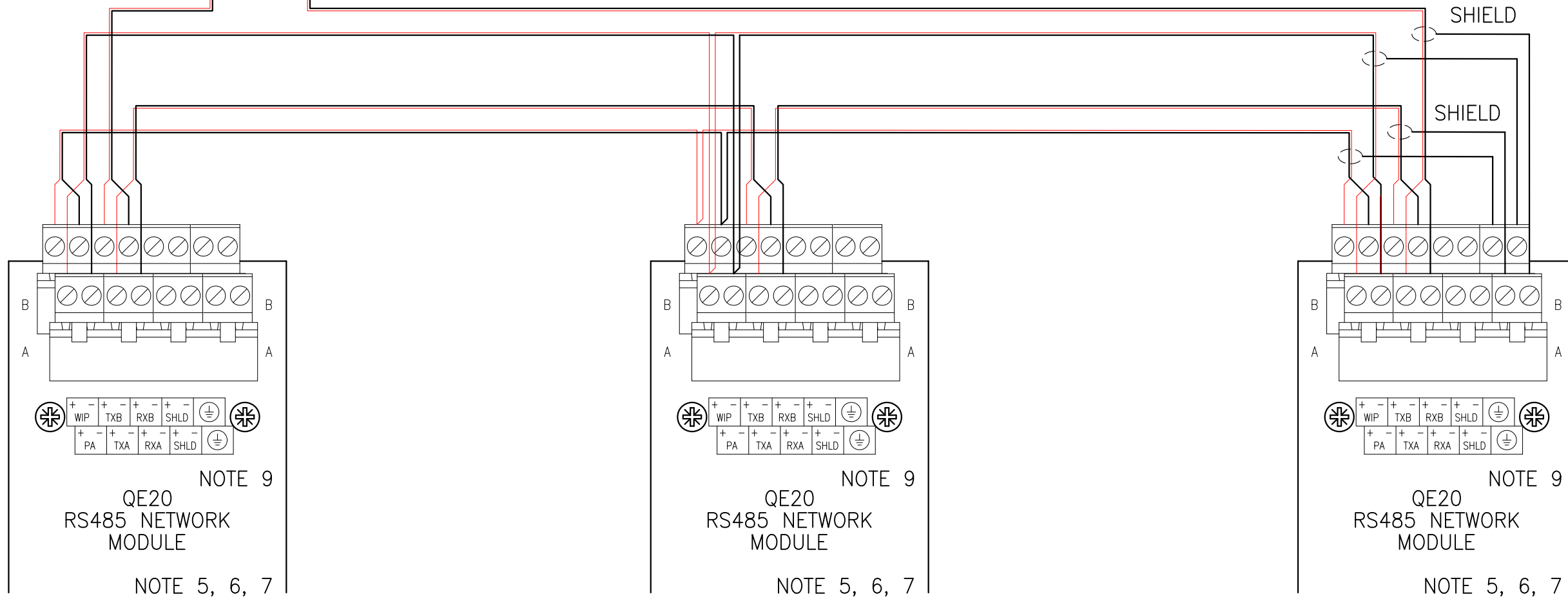

CONFIDENTIAL: THIS DOCUMENT MUST NOT BE COPIED NOR THE CONTENTS PASSED ON TO ANY THIRD PARTY WITHOUT THE CONSENT OF THE COMPANY.

UNLESS OTHERWISE STATED: ALL DIMENSIONS IN MILLIMETRES. DO NOT SCALE. TOLERANCES ARE TO BE: 1 DECIMAL PLACE ±0.5, 2 DECIMAL PLACES ±0.3, 3 DECIMAL PLACES ±0.1

3rd ANGLE PROJECTION

ISS/REV	AMENDMENTS	ECO	DRN	CHKD	AUTH	APVD	DATE
A	ORIGINAL.	-	KJS	RC	MH	DC	6-5-20

© 2020 Johnson Controls. All rights reserved. All specifications and other information shown were current as of document revision date and are subject to change without notice.

**JOHNSON CONTROLS**  
17 MARY MULLER DRIVE  
P.O. BOX 19545  
CHRISTCHURCH, PH: +64 3 3895096  
NEW ZEALAND. FAX: +64 3 3895938

**QE20 RS485 NETWORK MODULE  
RS485 "COPPER" NETWORKING  
WIRING DIAGRAM**

DRAWING No: 2001-2 SHEET 600 of N

A3 ISS/REV A PART No:

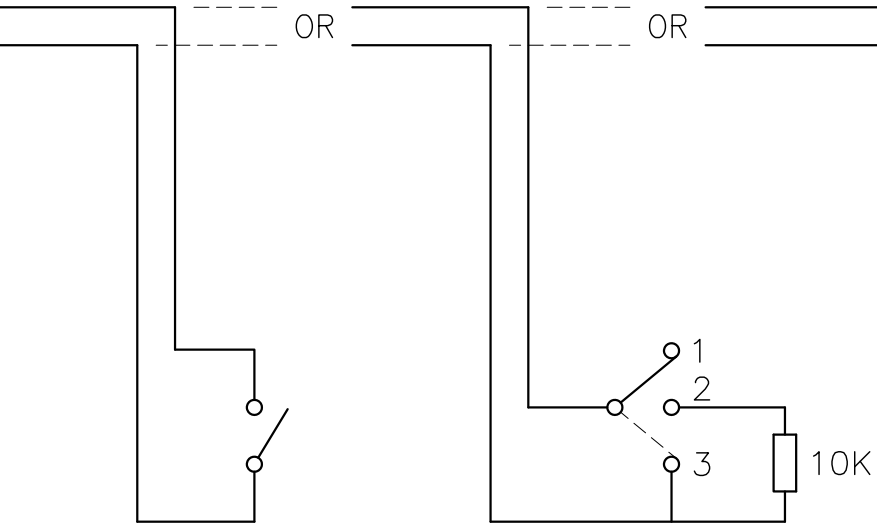
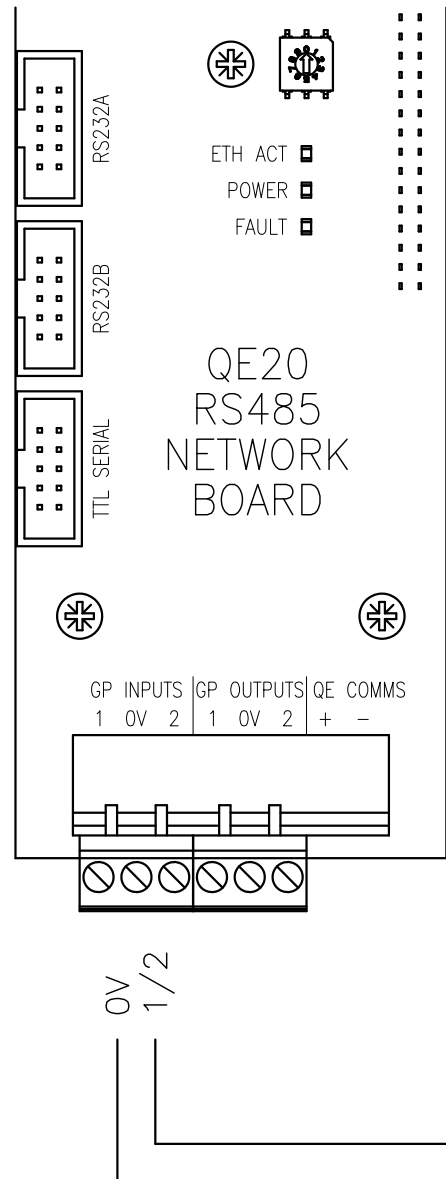

2 POSITION ON/OFF CONTACT (TABLE 1)

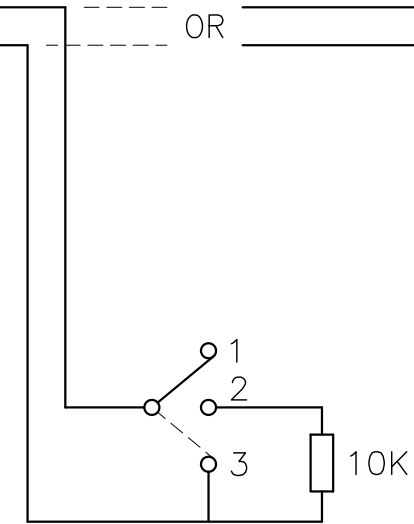

3 POSITION OPEN/NORMAL/SHORT CONTACT (TABLE 2)

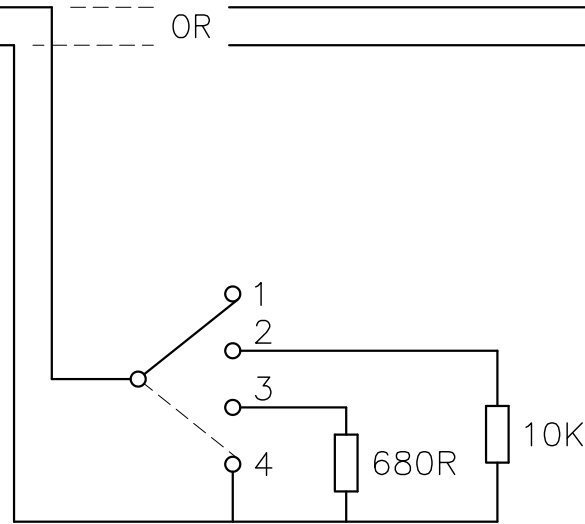

4 POSITION OPEN/NORMAL/ALARM SHORT SINGLE CONTACT (TABLE 3)

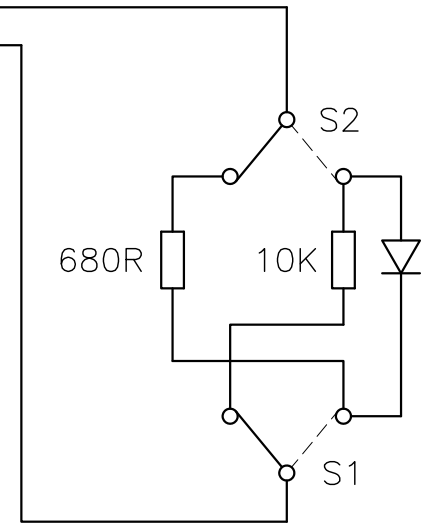

4 STATES FROM 2 ON/OFF CONTACTS (TABLE 3) S1, S2 SHOWN IN OFF POSITION

TABLE 1			
SWITCH POSITION	STATE	RESISTANCE	LOGIC TOKEN
OFF	OPEN	>20K	NCIPOCx.y
ON	SHORT	<270R	NCIPSCx.y

TABLE 2			
SWITCH POSITION	STATE	RESISTANCE	LOGIC TOKEN
1	OPEN	>20K	NCIPOCx.y
2	NORMAL	~10K	NCIPNMx.y
3	SHORT	<270R	NCIPSCx.y

TABLE 3					
SWITCH POSITION	S1	S2	STATE	RESISTANCE	LOGIC TOKEN
1	OFF	OFF	OPEN	>20K	NCIPOCx.y
2	OFF	ON	NORMAL	~10K	NCIPNMx.y
3	ON	OFF	ALARM	~680E	NCIPALx.y
4	ON	ON	SHORT	<270E	NCIPSCx.y

NOTES:

- x = MODULE ADDRESS 1-2.  
y = INPUT NUMBER 1-2.
- 10K RESISTOR CAN BE REPLACED WITH 10V ZENER FROM QE90.
- MUI BAND 1 IS S/C, ETC.

CONFIDENTIAL: THIS DOCUMENT MUST NOT BE COPIED NOR THE CONTENTS PASSED ON TO ANY THIRD PARTY WITHOUT THE CONSENT OF THE COMPANY.

UNLESS OTHERWISE STATED: ALL DIMENSIONS IN MILLIMETRES. DO NOT SCALE. TOLERANCES ARE TO BE: 1 DECIMAL PLACE ±0.5, 2 DECIMAL PLACES ±0.3, 3 DECIMAL PLACES ±0.1

3rd ANGLE PROJECTION

ISS/REV	AMENDMENTS	ECO	DRN	CHKD	AUTH	APVD	DATE
A	ORIGINAL.	-	KJS	RC	MH	DC	9-11-20

© 2020 Johnson Controls. All rights reserved. All specifications and other information shown were current as of document revision date and are subject to change without notice.

**JOHNSON CONTROLS**  
17 MARY MULLER DRIVE  
P.O. BOX 19545  
CHRISTCHURCH, PH: +64 3 3895096  
NEW ZEALAND. FAX: +64 3 3895938

**QE20 RS485 NW MODULE  
GP INPUTS, 2/3/4 WAY SWITCHES  
WIRING DIAGRAM**

DRAWING No: 2001-2 SHEET 601 of N

A3 ISS/REV A PART No:

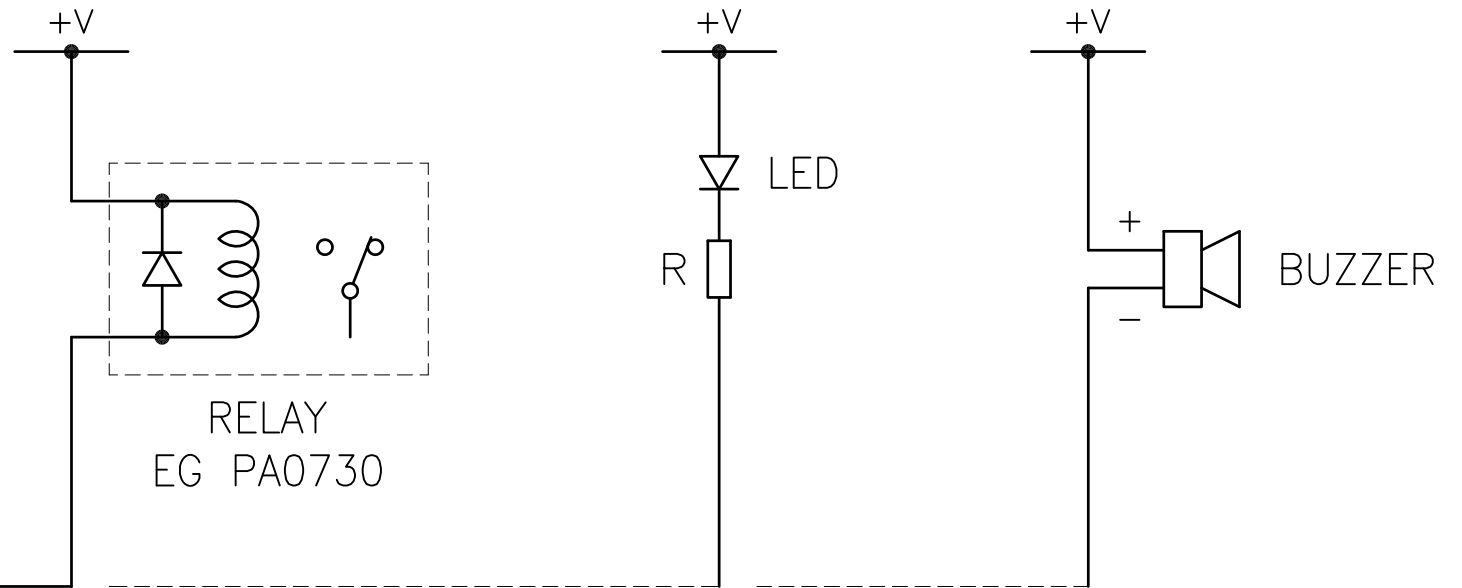
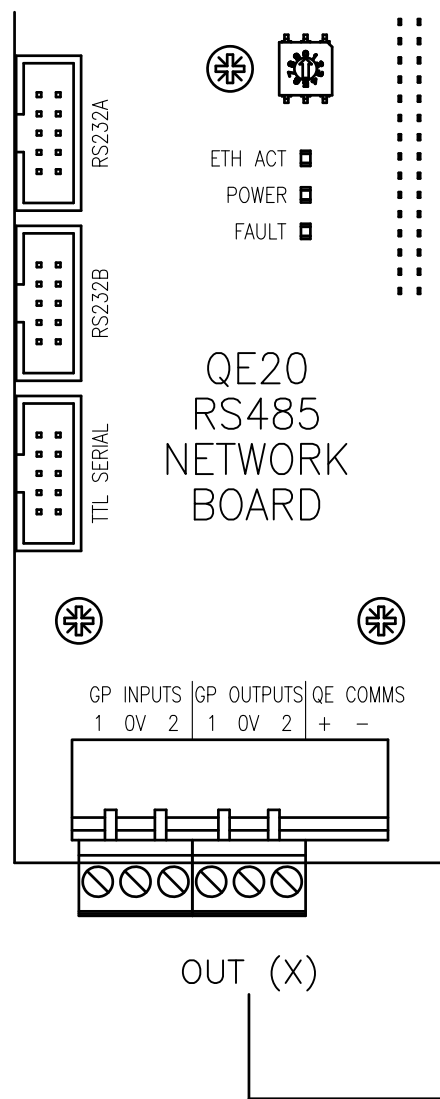

NOTES:

1. RATING OF OUTPUT DEVICE MUST MATCH SUPPLY VOLTAGE.
2. SELECT SERIES RESISTOR R FOR LED TO MATCH SUPPLY & REQUIRED CURRENT.
3. IF OUTPUT SUPERVISION CURRENT (250uA MAX) NOTICEABLE (EG ON LED) FIT 3K9 OR SIMILAR ACROSS LED.
4. OUTPUT RATINGS: 100mA MAX @ < 0.5V ON; 30V MAX OFF, 250uA SUPERVISION CURRENT.
5. LOAD SUPERVISION REQUIRES +V SUPPLY > 12V.

CONFIDENTIAL: THIS DOCUMENT MUST NOT BE COPIED NOR THE CONTENTS PASSED ON TO ANY THIRD PARTY WITHOUT THE CONSENT OF THE COMPANY.

UNLESS OTHERWISE STATED: ALL DIMENSIONS IN MILLIMETRES. DO NOT SCALE. TOLERANCES ARE TO BE: 1 DECIMAL PLACE ±0.5, 2 DECIMAL PLACES ±0.3, 3 DECIMAL PLACES ±0.1

3rd ANGLE PROJECTION

ISS/REV	AMENDMENTS	ECO	DRN	CHKD	AUTH	APVD	DATE
A	ORIGINAL.	-	KJS	RC	MH	DC	30-4-20

© 2020 Johnson Controls. All rights reserved. All specifications and other information shown were current as of document revision date and are subject to change without notice.

**JOHNSON CONTROLS**  
17 MARY MULLER DRIVE  
P.O. BOX 19545  
CHRISTCHURCH, PH: +64 3 3895096  
NEW ZEALAND. FAX: +64 3 3895938

**QE20 RS485 NETWORK MODULE  
GP OUTPUTS  
WIRING DIAGRAM**

DRAWING No: 2001-2 SHEET 602 of N

A3 | ISS/REV A | PART No:

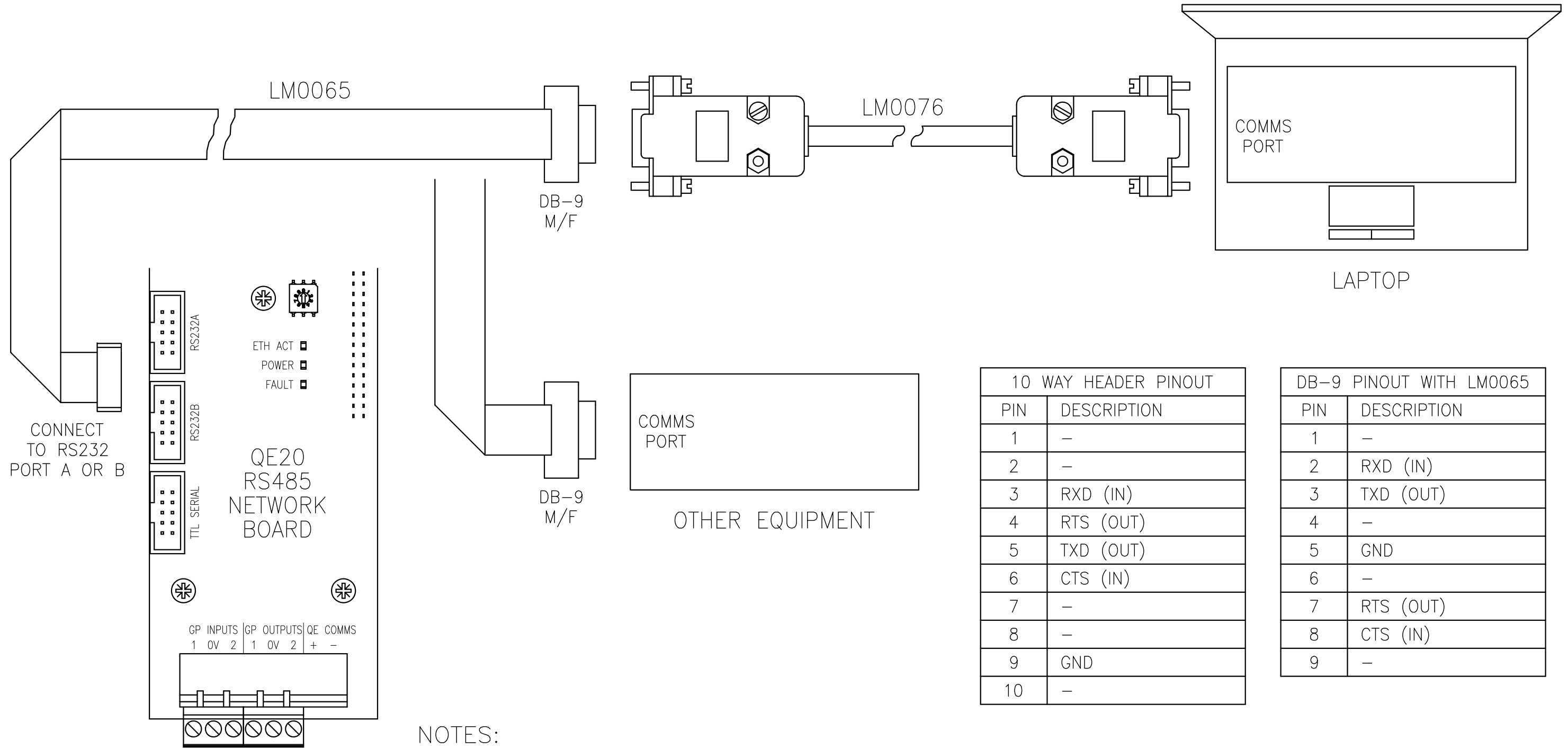

10 WAY HEADER PINOUT	
PIN	DESCRIPTION
1	-
2	-
3	RXD (IN)
4	RTS (OUT)
5	TXD (OUT)
6	CTS (IN)
7	-
8	-
9	GND
10	-

DB-9 PINOUT WITH LM0065	
PIN	DESCRIPTION
1	-
2	RXD (IN)
3	TXD (OUT)
4	-
5	GND
6	-
7	RTS (OUT)
8	CTS (IN)
9	-

NOTES:

1. TXD, RTS OUTPUT LEVEL = +/-5V.
2. ALTHOUGH LABELLED AS RTS, CTS, FUNCTIONALITY DEPENDS ON APPLICATION & QE20 SETUP.

CONFIDENTIAL: THIS DOCUMENT MUST NOT BE COPIED NOR THE CONTENTS PASSED ON TO ANY THIRD PARTY WITHOUT THE CONSENT OF THE COMPANY.

UNLESS OTHERWISE STATED: ALL DIMENSIONS IN MILLIMETRES. DO NOT SCALE. TOLERANCES ARE TO BE: 1 DECIMAL PLACE ±0.5, 2 DECIMAL PLACES ±0.3, 3 DECIMAL PLACES ±0.1

3rd ANGLE PROJECTION

ISS/REV	AMENDMENTS	ECO	DRN	CHKD	AUTH	APVD	DATE
A	ORIGINAL.	-	KJS	RC	MH	DC	30-4-20

© 2020 Johnson Controls. All rights reserved. All specifications and other information shown were current as of document revision date and are subject to change without notice.

**JOHNSON CONTROLS**  
 17 MARY MULLER DRIVE  
 P.O. BOX 19545  
 CHRISTCHURCH, PH: +64 3 3895096  
 NEW ZEALAND. FAX: +64 3 3895938

**QE20 RS485 NETWORK MODULE  
 RS232 PORT  
 WIRING DIAGRAM**

DRAWING No: **2001-2** SHEET **603** of **N**

<b>A3</b>	ISS/REV <b>A</b>	PART No:
-----------	------------------	----------

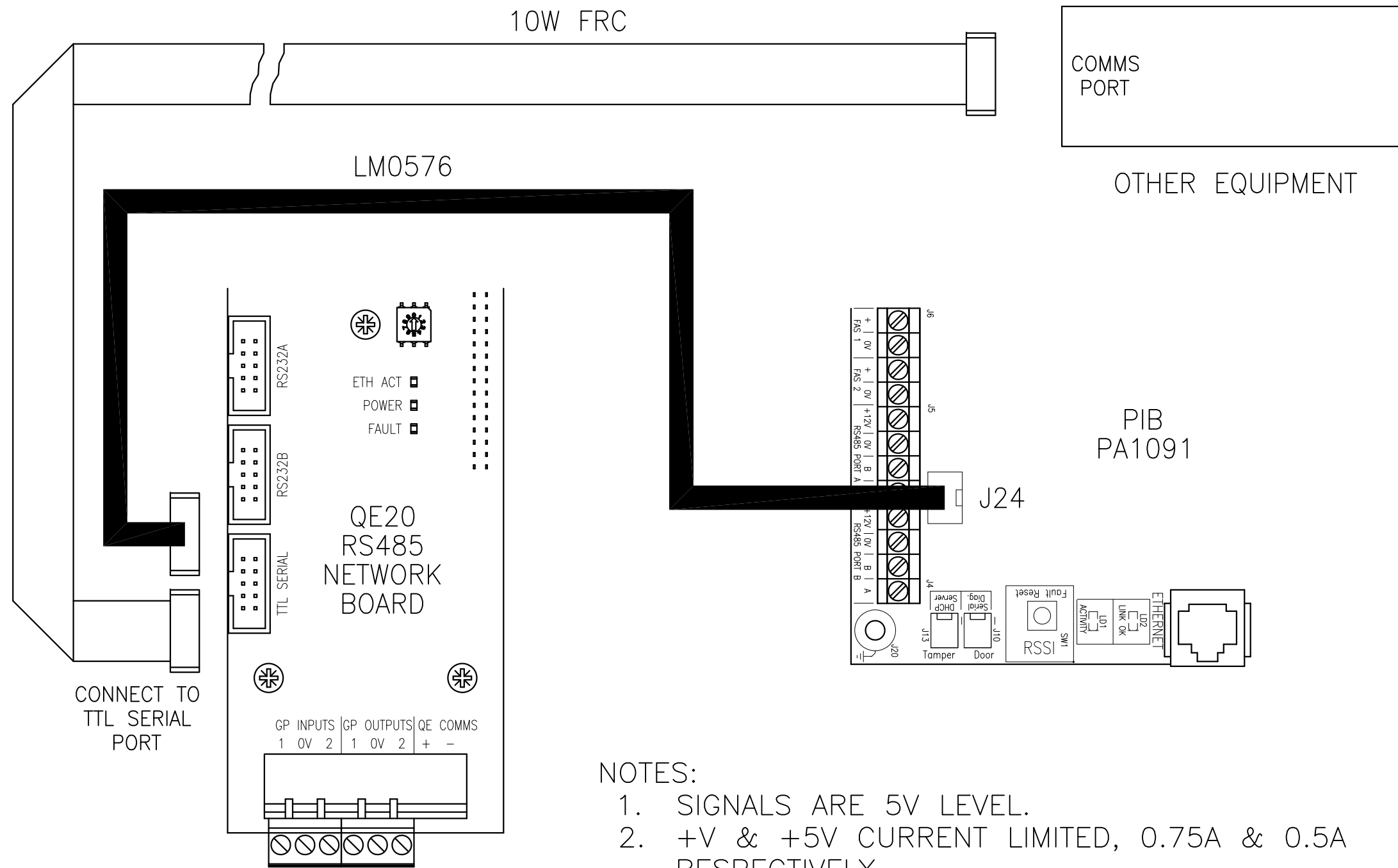

TTL SERIAL 10 WAY HEADER PINOUT	
PIN	DESCRIPTION
1	+V
2	-
3	RXD (IN)
4	TXD (OUT)
5	RTS (OUT)
6	CTS (IN)
7	0V
8	0V
9	-
10	+5V

- NOTES:
1. SIGNALS ARE 5V LEVEL.
  2. +V & +5V CURRENT LIMITED, 0.75A & 0.5A RESPECTIVELY.
  3. RTS & CTS HAVE NO ASSIGNED FUNCTIONS.

CONFIDENTIAL: THIS DOCUMENT MUST NOT BE COPIED NOR THE CONTENTS PASSED ON TO ANY THIRD PARTY WITHOUT THE CONSENT OF THE COMPANY.

UNLESS OTHERWISE STATED: ALL DIMENSIONS IN MILLIMETRES. DO NOT SCALE. TOLERANCES ARE TO BE: 1 DECIMAL PLACE ±0.5, 2 DECIMAL PLACES ±0.3, 3 DECIMAL PLACES ±0.1

3rd ANGLE PROJECTION

ISS/REV	AMENDMENTS	ECO	DRN	CHKD	AUTH	APVD	DATE
A	ORIGINAL.	-	KJS	RC	MH	DC	30-4-20

© 2020 Johnson Controls. All rights reserved. All specifications and other information shown were current as of document revision date and are subject to change without notice.

**JOHNSON CONTROLS**  
 17 MARY MULLER DRIVE  
 P.O. BOX 19545  
 CHRISTCHURCH, PH: +64 3 3895096  
 NEW ZEALAND. FAX: +64 3 3895938

**QE20 RS485 NETWORK MODULE  
 TTL SERIAL  
 WIRING DIAGRAM**

DRAWING No: **2001-2** SHEET **604** of **N**

<b>A3</b>	ISS/REV <b>A</b>	PART No:
-----------	------------------	----------

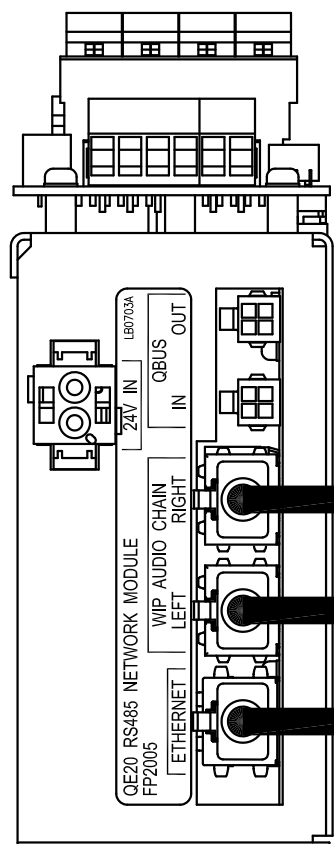
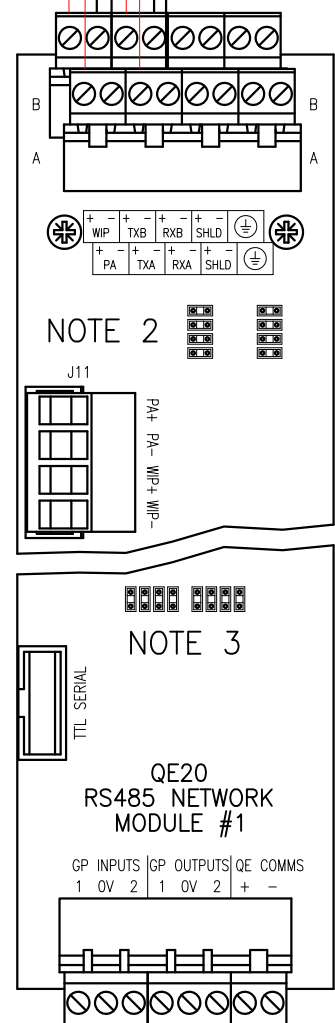
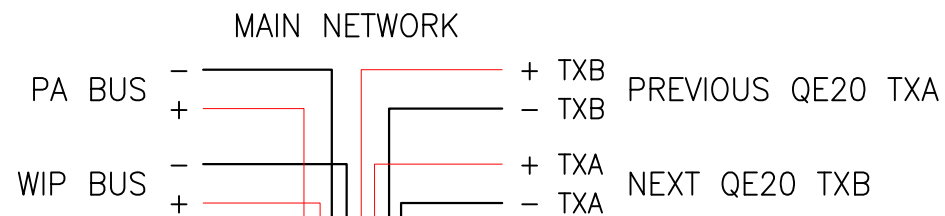

NOTE 5

CONNECT WIP AUDIO INTO CHAIN, LEFT TO RIGHT

TO CONTROLLER ETHERNET PORT 2

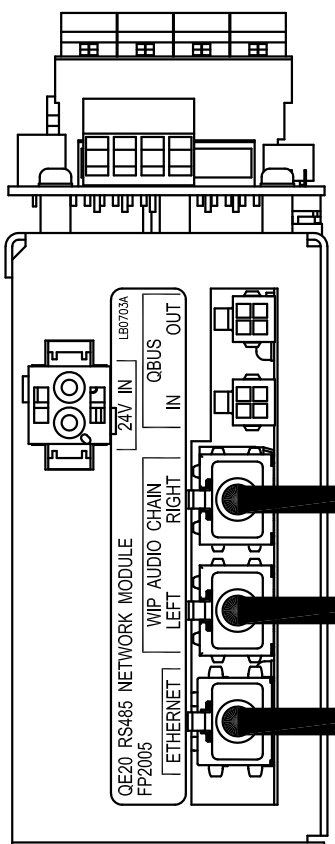
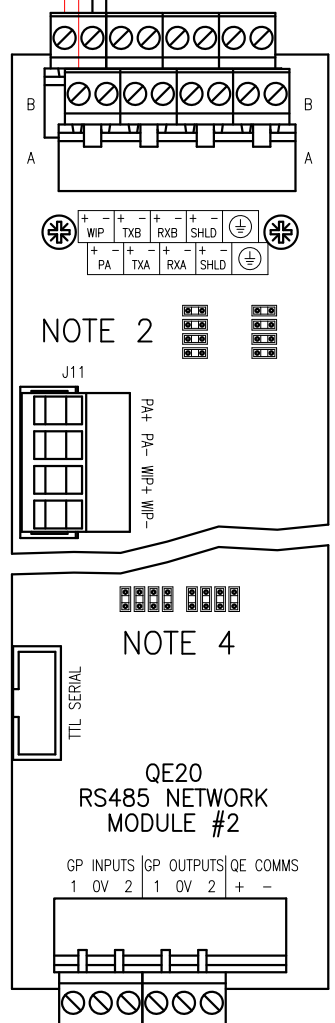
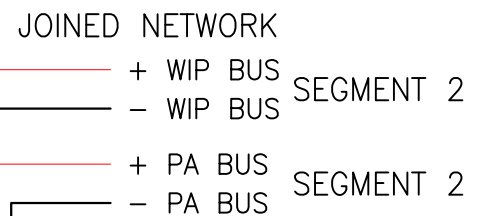

NOTE 5

CONNECT WIP AUDIO INTO CHAIN, LEFT TO RIGHT

TO CONTROLLER ETHERNET PORT 3

- NOTES:
1. REFER TO SHEET 600 FOR RS485 AND AUDIO COPPER NETWORK WIRING.
  2. FIT PORT A/B 2 WIRE MODE LINKS.
  3. FIT M/S LINKS AS REQUIRED FOR MAIN NETWORK.
  4. FIT M/S LINKS.
  5. INTERNAL WIRING (+24V AND FIBRE KIT WIRING NOT SHOWN).

CONFIDENTIAL: THIS DOCUMENT MUST NOT BE COPIED NOR THE CONTENTS PASSED ON TO ANY THIRD PARTY WITHOUT THE CONSENT OF THE COMPANY.

UNLESS OTHERWISE STATED: ALL DIMENSIONS IN MILLIMETRES. DO NOT SCALE. TOLERANCES ARE TO BE: 1 DECIMAL PLACE ±0.5, 2 DECIMAL PLACES ±0.3, 3 DECIMAL PLACES ±0.1

3rd ANGLE PROJECTION

ISS/REV	AMENDMENTS	ECO	DRN	CHKD	AUTH	APVD	DATE
A	ORIGINAL	-	KJS	RC	MH	DC	21-11-22

© 2020 Johnson Controls. All rights reserved. All specifications and other information shown were current as of document revision date and are subject to change without notice.

**JOHNSON CONTROLS**  
 17 MARY MULLER DRIVE  
 P.O. BOX 19545  
 CHRISTCHURCH, PH: +64 3 3895096  
 NEW ZEALAND. FAX: +64 3 3895938

**QE20 RS485 NETWORK MODULE  
 JOINED AUDIO BUSES  
 WIRING DIAGRAM**

DRAWING No: 2001-2 SHEET 607 of N

<b>A3</b>	ISS/REV <b>A</b>	PART No:	
-----------	------------------	----------	--



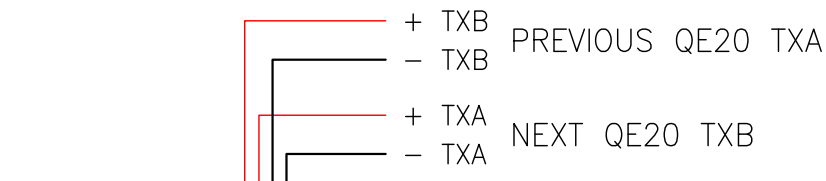

COPPER NETWORK  
NOTE 1

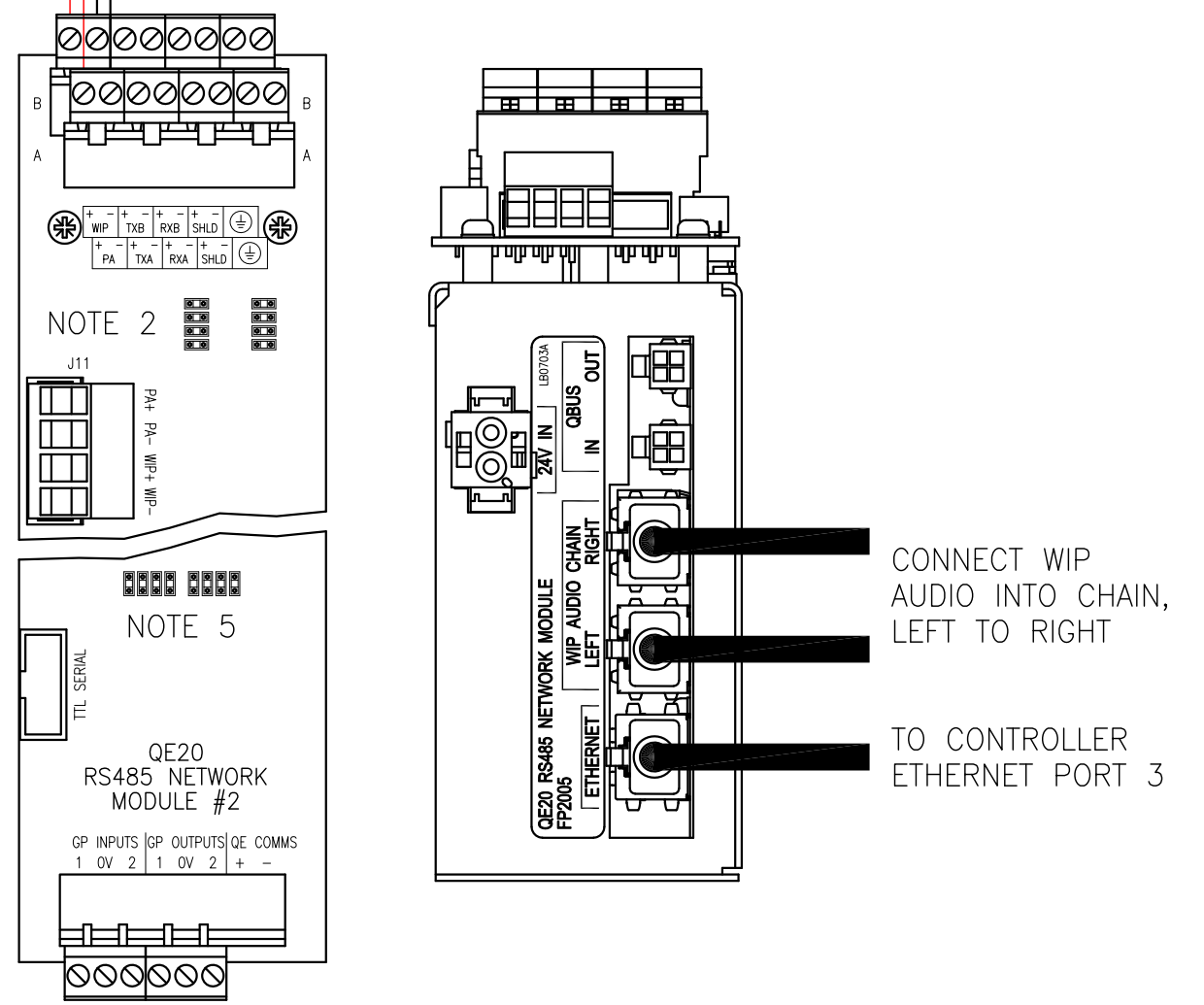
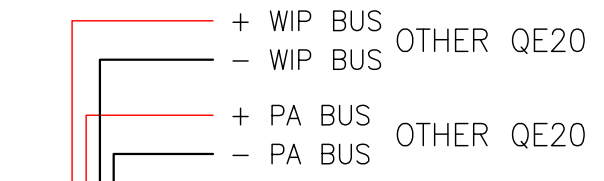
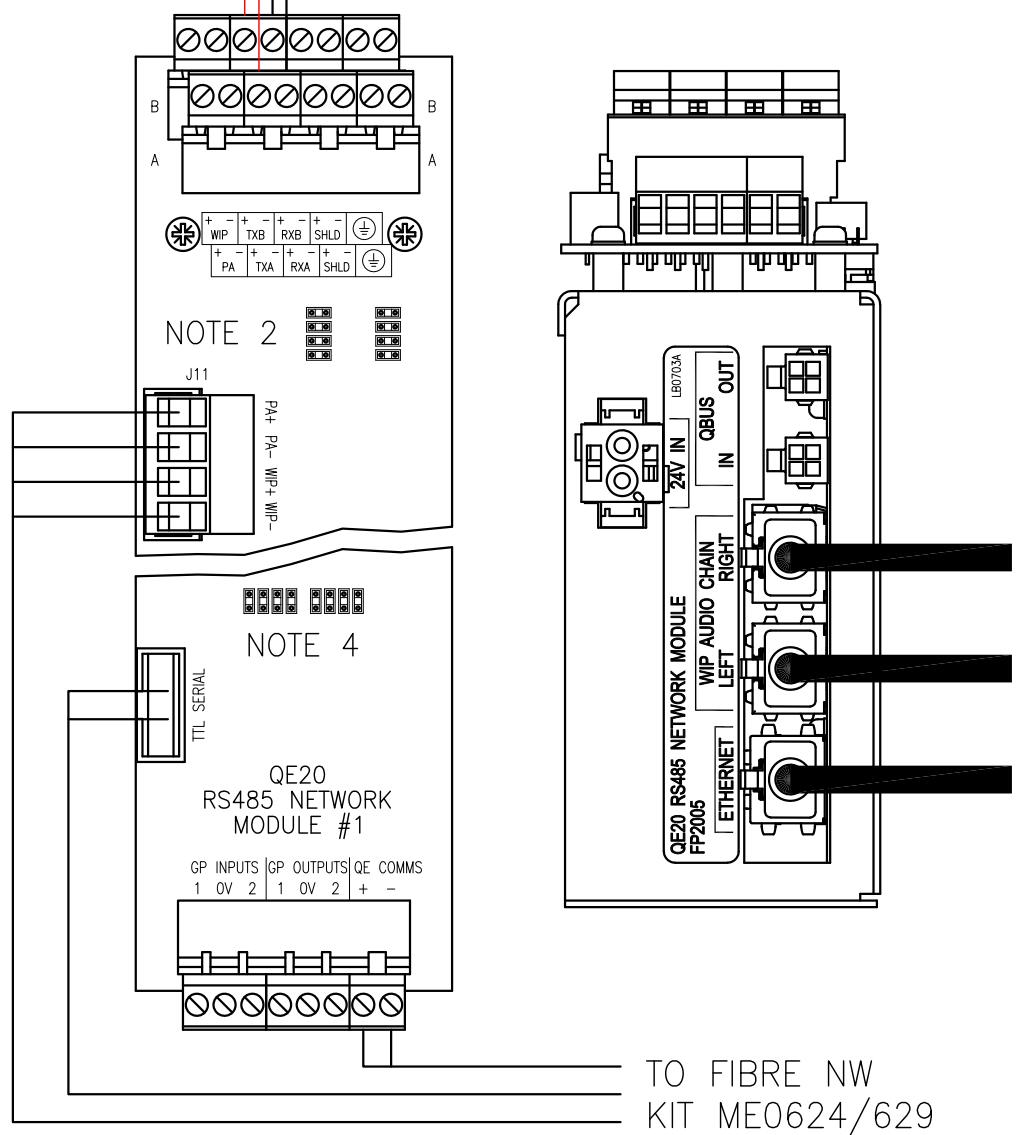

- NOTES:
1. REFER TO SHEET 600 FOR RS485 AND AUDIO COPPER NETWORK WIRING.
  2. FIT PORT A/B 2 WIRE MODE LINKS.
  3. REFER TO SHEETS 605 AND 606 FOR FIBRE NETWORKING.
  4. REMOVE M/S LINKS.
  5. FIT M LINKS.
  6. NOT ALL INTERNAL WIRING SHOWN.

CONFIDENTIAL: THIS DOCUMENT MUST NOT BE COPIED NOR THE CONTENTS PASSED ON TO ANY THIRD PARTY WITHOUT THE CONSENT OF THE COMPANY.

UNLESS OTHERWISE STATED: ALL DIMENSIONS IN MILLIMETRES. DO NOT SCALE. TOLERANCES ARE TO BE: 1 DECIMAL PLACE ±0.5, 2 DECIMAL PLACES ±0.3, 3 DECIMAL PLACES ±0.1

3rd ANGLE PROJECTION

ISS/REV	AMENDMENTS	ECO	DRN	CHKD	AUTH	APVD	DATE
A	ORIGINAL.	-	KJS	RC	MH	DC	21-11-22

© 2020 Johnson Controls. All rights reserved. All specifications and other information shown were current as of document revision date and are subject to change without notice.

**JOHNSON CONTROLS**  
17 MARY MULLER DRIVE  
P.O. BOX 19545  
CHRISTCHURCH, PH: +64 3 3895096  
NEW ZEALAND. FAX: +64 3 3895938

**QE20 RS485 NETWORK MODULE  
FIBRE - COPPER BRIDGE  
WIRING DIAGRAM**

DRAWING No: 2001-2 SHEET 608 of N

<b>A3</b>	ISS/REV <b>A</b>	PART No:	
-----------	------------------	----------	--